



USN

--	--	--	--	--	--	--	--	--	--

15ME64

Sixth Semester B.E. Degree Examination, June/July 2019 Design of Machine Elements – II

Time: 3 hrs.

Max. Marks: 80

- Note: 1. Answer any FIVE full questions, choosing ONE full question from each module.
2. Use of design data handbook is permitted.
3. Assume suitably missing data.*

Module-1

- 1 a. Differentiate between straight and curved beam. (04 Marks)
 b. A closed ring is made up of 50mm diameter steel bar having allowable tensile stress of 200 MPa. The inner diameter of ring is 100mm. For the load of 30 kN, find the maximum stress in the bar and specify the location. If the ring is cut as shown part B of the Fig.Q1(b), check whether it is safe to support the applied load. (12 Marks)

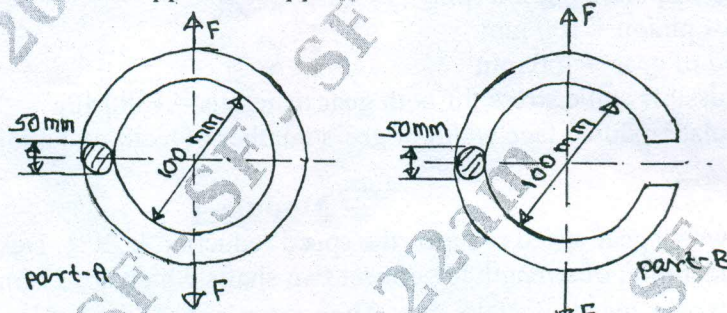

Fig.Q1(b)

OR

- 2 a. A high pressure cylinder consists of a steel tube with inner and outer diameter of 20 mm and 40mm respectively. It is jacketed by an outer steel tube with an outer diameter of 60mm. The tubes are assembled by shrinking process in such a way that maximum principal stress is limited to 100 MPa. Calculate the shrinkage pressure and original dimensions of the tube. Take $E = 207 \text{ kN/mm}^2$. (08 Marks)
 b. A cylinder of 200 mm diameter is covered with a cast iron plate and is fixed at circumference. Its thickness is 9mm and is subjected to a uniform force of 6 kN over a diameter of 100 mm. Find the stress induced in the plate and deflection under load. Take $E = 120 \text{ kN/mm}^2$. (08 Marks)

Module-2

- 3 a. Sketch and explain Block and Tackle mechanism of wire rope. (06 Marks)
 b. It is required to design a V-belt drive to connect a 7.5 kW, 1440 rpm induction motor to a fan, running at approximately 480 rpm, for a service of 24 hours per day. Space is available for a centre distance of about 1m. (10 Marks)

OR

- 4 a. For a Leaf spring prove that stress in full length leaves is 50% greater than that of graduated leaves. (06 Marks)

Important Note : 1. On completing your answers, compulsorily draw diagonal cross lines on the remaining blank pages.
2. Any revealing of identification, appeal to evaluator and /or equations written eg. 42+8= 50, will be treated as malpractice.

- b. At the bottom of a mine shaft a group of 10 identical close coiled helical springs are set in parallel to absorb the shock caused by the falling of the cage in case of a failure. The loaded cage weighs 75 kN, while the counter weight has a weight of 15 kN. If the loaded cage falls through a height of 5m from rest, find the maximum stress induced in each spring if it is made of 50mm diameter steel rod. The spring index is 6 and the number of active turns in each spring is 20. Modulus of rigidity $G = 8 \times 10^4 \text{ N/mm}^2$. (10 Marks)

Module-3

- 5 Design a pair of helical gears to transmit 15 KW at 1200 rpm of pinion. The gear is to rotate at 600 rpm. The helix angle is 17.5° . The centre distance between the gears is 150mm. The pinion is made of high carbon steel ($\sigma_0 = 103.5 \text{ MPa}$) and gear of 0.40% carbon steel, untreated ($\sigma_0 = 69.6 \text{ MPa}$). (16 Marks)

OR

- 6 a. Derive an expression for Beam strength of a spur gear tooth : (Lewis equation). (06 Marks)
 b. The following parameters refers to a pair of right angle bevel gears:
 Power to be transmitted = 8 kW
 Speed of pinion = 1600 rpm
 Pcd of pinion = 100 mm
 Speed of gear = 400 rpm
 Permissible static stress for both gear materials = 138 MPa
 Calculate module face width of gears number of teeth on pinion and gear. (10 Marks)

Module-4

- 7 In a worm gear speed reducer, the speed reduction is 30:1. Design the worm gear drive from consideration of strength to connect two shafts which are 275mm apart and transmits 7.5 kW at a worm speed of 3000 rpm. The worm is made of hardened steel ($\sigma_0 = 200 \text{ MPa}$) and worm wheel of phosphor bronze ($\sigma_0 = 84 \text{ MPa}$). The teeth are 20° stub. (16 Marks)

OR

- 8 a. A multi disc clutch has three discs on the driving shaft and two on the driven shaft. The inside diameter of the contact surface is 120mm. The maximum pressure between the surface is limited to 0.1 N/mm^2 , calculate outside diameter of contact surface for transmitting 25 kW at 1575 rpm. Assume uniform wear condition at coefficient of friction of 0.3. (08 Marks)
 b. A differential band brake operates on a sheave of 420 mm diameter and rotates at 5 rev/sec. The brake has to absorb 21 kW. Coefficient of friction is 0.25. Determine the force 'F' required to set the brake for clockwise rotation, refer Fig.Q8(b). (08 Marks)

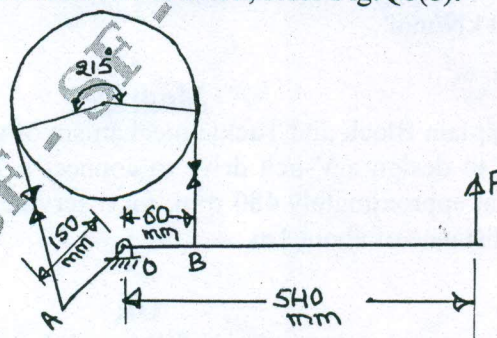

Fig.Q8(b)

**Module-5**

- 9 a. A 75 mm long full journal bearing of diameter 75mm supports a load of 10 kN. The speed of the journal is 1200 rpm. The absolute viscosity of the oil is 10×10^{-3} Pas and the diametral clearance ratio is 0.001. Determine the coefficient of friction by using
(i) Petroff's equation (ii) McKee's equation (iii) Raimondi and Boyd curve. (08 Marks)
- b. A full journal bearing of 50mm diameter, 75 mm long supports a radial load of 1000 N. The speed of the shaft is 600 rpm. The surface temperature of bearing is limited to 60°C and the room temperature is 30°C . Determine the viscosity of the oil, if the bearing is well ventilated and no artificial cooling is to be used. The ratio of journal diameter to diametral clearance is 1000. (08 Marks)

OR

- 10 a. A ball bearing operates in the following work cycle.

Element	Radial load N	Speed rpm	Element time %
1	3000	720	30
2	7000	1440	40
3	5000	900	30

The dynamic load capacity of bearing is 16500 N. Calculate

- (i) Average speed of rotation
(ii) Equivalent radial load
(iii) Bearing life. (08 Marks)
- b. A single row deep groove ball bearing is subjected to a radial force of 8 kN and a thrust force of 3 kN. The values of X and Y are 0.56 and 1.5 respectively. The shaft rotates at 1200 rpm. The diameter of the shaft is 75mm and bearing number 6315 is selected for this application.
(i) Estimate the life of this bearing with 90% reliability.
(ii) Estimate the reliability for 20,000 hours life. (08 Marks)
