



10ES43

USN 

--	--	--	--	--	--	--	--	--	--

**Fourth Semester B.E. Degree Examination, Dec.2017/Jan.2018**  
**Control Systems**

Time: 3 hrs.

Max. Marks:100

**Note: Answer FIVE full questions, selecting at least TWO questions from each part.**

**PART - A**

- 1 a. Define and compare open loop control system with closed loop control system with an example. (06 Marks)
- b. Obtain the differential equation for the Fig. Q1 (b) shown in Fig. Q1 (b). (04 Marks)

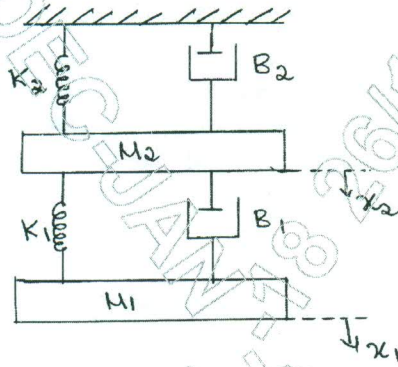

Fig. Q1 (b)

- c. Obtain the differential equation describing the system shown in the Fig. Q1 (c) and also sketch the electrical circuit based on, (i) Torque voltage analogy (ii) Torque current analogy. (10 Marks)

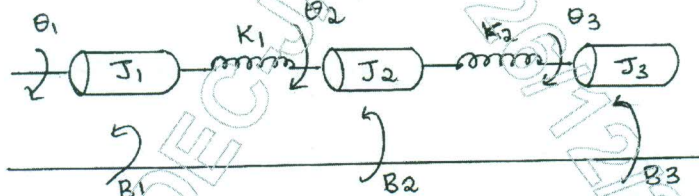

Fig. Q1 (c)

- 2 a. Define the following terms: (i) Self loop (ii) Node (iii) Branch (iv) Feedback loop. (04 Marks)
- b. Simplify the block diagram shown in the Fig. Q2 (b) below, also obtain the closed loop transfer function  $C(s)/R(s)$ . (08 Marks)

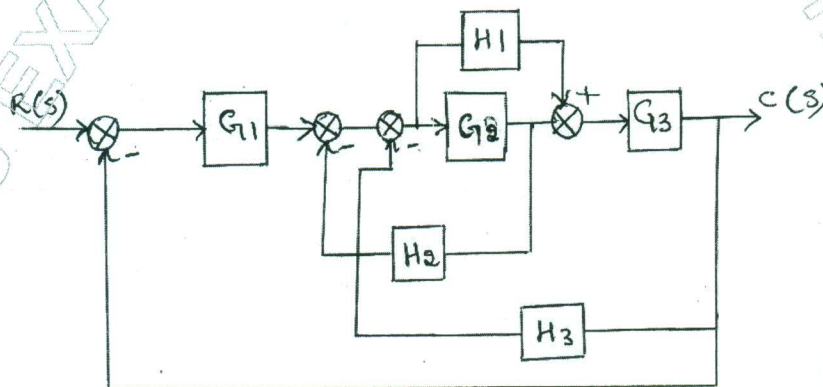

Fig. Q2 (b)

Important Note : 1. On completing your answers, compulsorily draw diagonal cross lines on the remaining blank pages.  
2. Any revealing of identification, appeal to evaluator and/or equations written eg, 42+8 = 50, will be treated as malpractice.

- c. Find the overall transfer function by using Mason's gain formula for Fig. Q2 (c) shown below. (08 Marks)

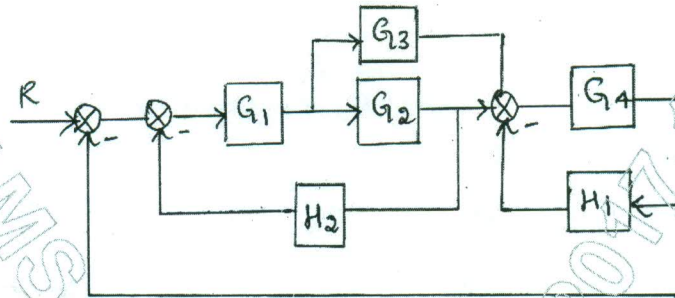

Fig. Q2 (c)

- 3 a. Explain the following time domain specification of a 2<sup>nd</sup> order system,  
 (i) Rise time (ii) Delay time (iii) Peak time (iv) Peak overshoot. (06 Marks)  
 b. For a system shown in Fig. Q3 (b), find the value of 'A' such that damping ratio is 0.5, determine the values of Tr, T<sub>p</sub>, M<sub>p</sub> and T<sub>s</sub> in the unit step response. (08 Marks)

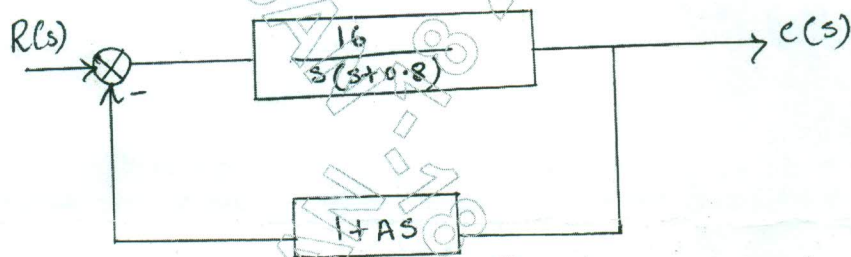

Fig. Q3 (b)

- c. For a system shown in the Fig. Q3 (c) below determine steady state error for a unit step input given to the system. (06 Marks)

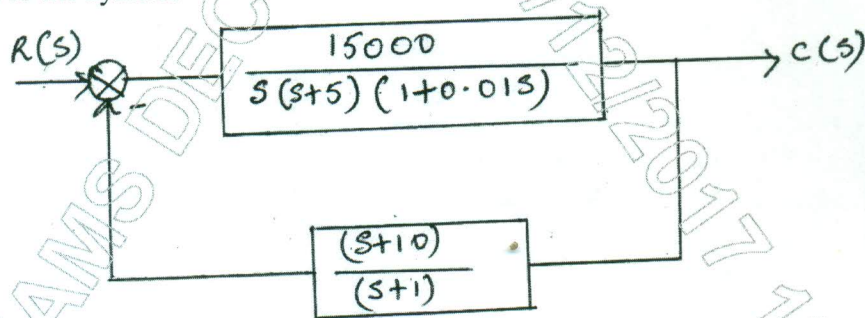

Fig. Q3 (c)

- 4 a. What are the necessary conditions and limitations for the system to be stable in case of Routh Hurwitz criterion? (06 Marks)  
 b. Examine the stability of Routh criterion  $s^5 + s^4 + 2s^3 + 2s^2 + 3s + 5 = 0$ . (06 Marks)  
 c. The open loop transfer function of a unity feedback control system is given by,

$$G(s)H(s) = \frac{K}{s(s+1)(2s+1)(3s+1)}$$

Determine the values of 'K'.

- (i) For which the system is stable.  
 (ii) Which will cause the sustained oscillation in closed loop system and frequency of sustained oscillations? (08 Marks)

**PART – B**

- 5 a. What is Root locus? State the different rules for construction of root loci? (08 Marks)
- b. For a unity feedback system  $G(s) = \frac{K}{s(s+4)(s+2)}$ . Sketch the root locus showing all the details on it. (12 Marks)
- 6 a. State and explain Nyquist stability criterion. (08 Marks)
- b. Sketch the Nyquist plot and comment on closed loop stability of a system whose open loop transfer function is,
- $$G(s)H(s) = \frac{10}{s(s+2)(s+1)}$$
- (12 Marks)
- 7 a. Define the following terms:
- |                                  |                   |            |
|----------------------------------|-------------------|------------|
| (i) Gain cross over frequency    | (ii) Gain margin  | (08 Marks) |
| (iii) Phase cross over frequency | (iv) Phase margin |            |
- b. A unity feedback control system has  $G(s) = \frac{80}{s(s+2)(s+20)}$ . Draw the Bode plot. Determine GM, PM,  $\omega_{gc}$  and  $\omega_{pc}$ . Comment on the stability. (12 Marks)
- 8 a. Define the following terms:
- |                     |            |
|---------------------|------------|
| (i) State           | (06 Marks) |
| (ii) State variable |            |
| (iii) State space   |            |
- b. Obtain the state space representation of the following system given by,
- $$\frac{Y(s)}{U(s)} = \frac{2(s+3)}{(s+1)(s+2)}$$
- Find the partial fraction of it. (07 Marks)
- c. Obtain phase variable representation for a system whose transfer function is given by,
- $$\frac{Y(s)}{u(s)} = \frac{6s^3 + 4s^2 + 3s + 10}{s^3 + 8s^2 + 4s + 20}$$
- (07 Marks)

\* \* \* \* \*