



USN

--	--	--	--	--	--	--	--	--	--

15CV52

Fifth Semester B.E. Degree Examination, June/July 2019 Analysis of Indeterminate Structures

Time: 3 hrs.

Max. Marks: 80

Note: Answer any FIVE full questions, choosing ONE full question from each module.

Module-1

- 1 a. Analyse the continuous beam shown in Fig.Q1(a) by slope deflection method. Draw bending moment diagram. EI is constant. (06 Marks)

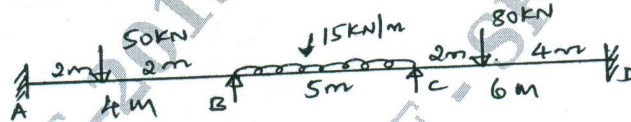

Fig.Q1(a)

- b. Analyse the portal frame shown in Fig.Q1(b) by slope deflection method. Draw bending moment diagram. (10 Marks)

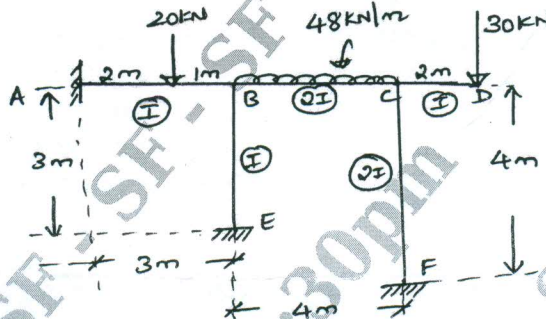

Fig.Q1(b)

OR

- 2 a. Analyse the continuous beam shown in Fig.Q2(a) by slope deflection method. Support 'B' sinks by 3 mm. Take $EI = 3000 \text{ kN-m}^2$. Draw bending moment diagram. (06 Marks)

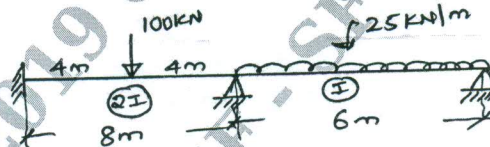

Fig.Q2(a)

- b. Analyse the portal frame shown in the Fig.Q2(b) by slope deflection method. Draw bending moment diagram. (10 Marks)

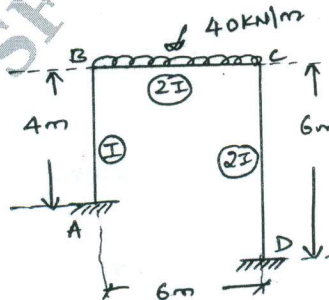

Fig.Q2(b)

Important Note : 1. On completing your answers, compulsorily draw diagonal cross lines on the remaining blank pages.
2. Any revealing of identification, appeal to evaluator and /or equations written eg, 42+8 = 50, will be treated as malpractice.



Module-2

- 3 a. Analyse the continuous beam using moment distribution method. Draw bending moment and shear force diagram. Refer Fig.Q3(a). (06 Marks)

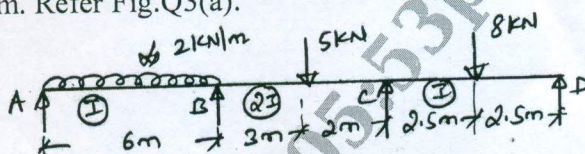

Fig.Q3(a)

- b. Analyse the portal frame shown in Fig.Q3(b) using moment distribution method. Draw bending moment diagram. Take $EIS = 20 \text{ kN-m}^3$. (10 Marks)

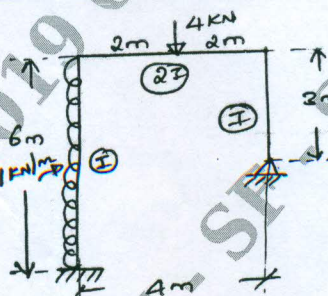

Fig.Q3(b)

OR

- 4 a. A horizontal beam is loaded as shown in Fig.Q4(a). It support 'A' sinks by 10 mm and B by 30 mm and C by 20 mm. Determine the end moments in the beam. Given $I = 2.4 \times 10^6 \text{ mm}^4$ and $E = 2 \times 10^5 \text{ N/mm}^2$. (08 Marks)

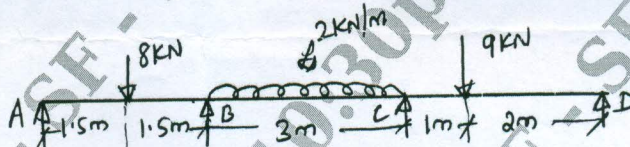

Fig.Q4(a)

- b. Analyse the portal frame shown in Fig.Q4(b) using moment distribution method. Draw bending moment. (08 Marks)

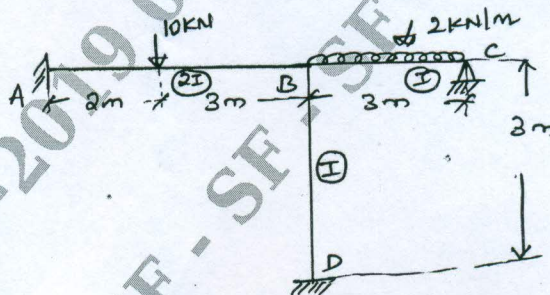

Fig.Q4(b)

Module-3

- 5 a. Analyse the continuous beam shown in Fig.Q5(a) using Kani's method. Draw bending moment diagram. (08 Marks)

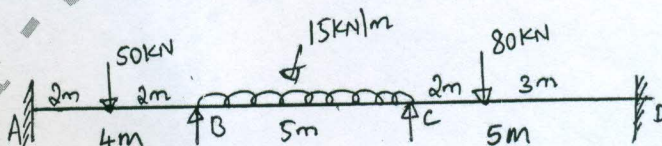

Fig.Q5(a)

- b. Analyse the frame shown in Fig.Q5(b) using Kani's method. Draw bending moment diagram. (08 Marks)

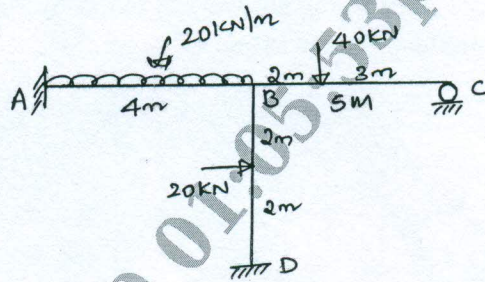

Fig.Q5(b)



OR

- 6 Analyse the frame shown in Fig.Q6 by Kani's method. Draw bending moment diagram. (16 Marks)

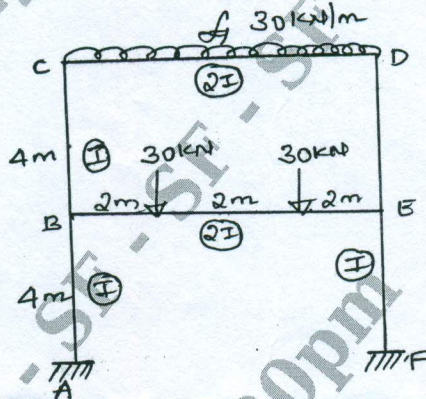

Fig.Q6

(16 Marks)

Module-4

- 7 a. Analyse the beam shown in Fig.Q7(a) by flexibility method and draw bending moment diagram. (08 Marks)

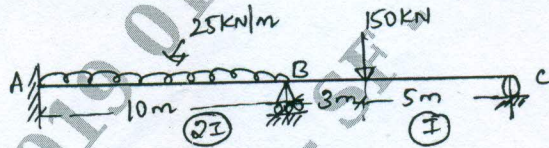

Fig.Q7(a)

- b. Analyse the frame shown in Fig.Q7(b) by flexibility method and draw bending moment diagram. (08 Marks)

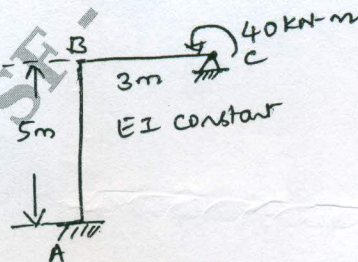

Fig.Q7(b)

OR

- 8 Analyse the pin-jointed frame shown in Fig.Q8 by flexibility method. The cross-sectional areas A and E for all members is the same. (16 Marks)

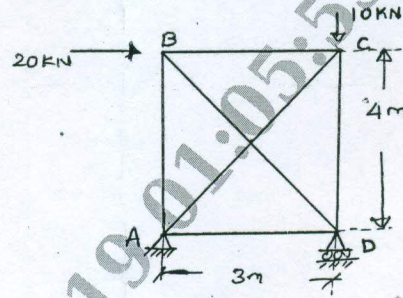

Fig.Q8

Module-5

- 9 a. Analyse the continuous beam shown in Fig.Q9(a) by stiffness method. Draw bending moment diagram. (08 Marks)

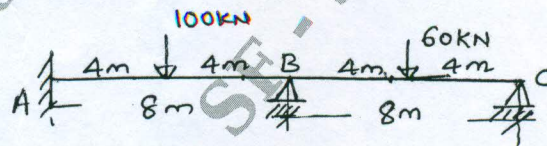

Fig.Q9(a)

- b. Analyse the portal frame shown in Fig.Q9(b) by stiffness method. Draw bending moment diagram. (08 Marks)

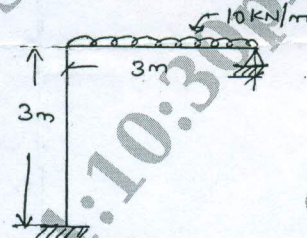

Fig.Q9(b)

OR

- 10 Using stiffness method determine the displacements at the joint 'B' of a pin-jointed frame shown in Fig.Q10. Also calculate the forces in the members AB and BC due to given loading. The values of area of cross-section are indicated. Take $E = 2 \times 10^5 \text{ N/mm}^2$. (16 Marks)

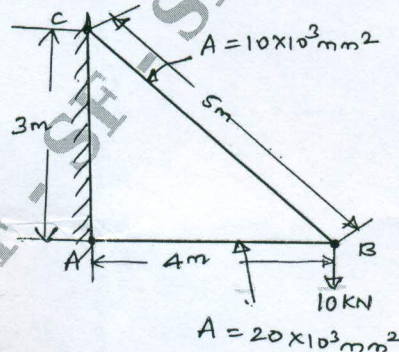

Fig.Q10
